

USB Connector

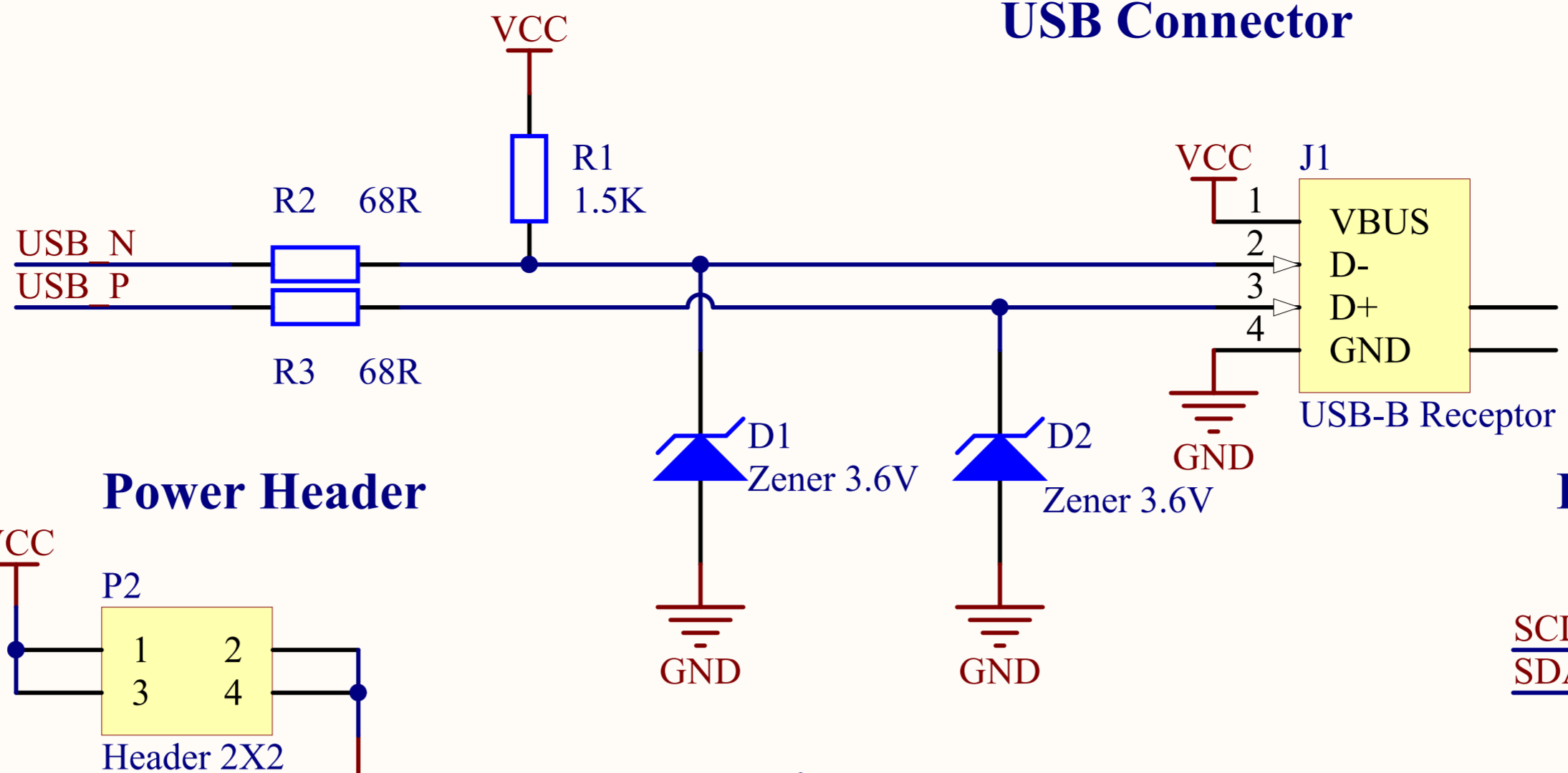

ISP Header

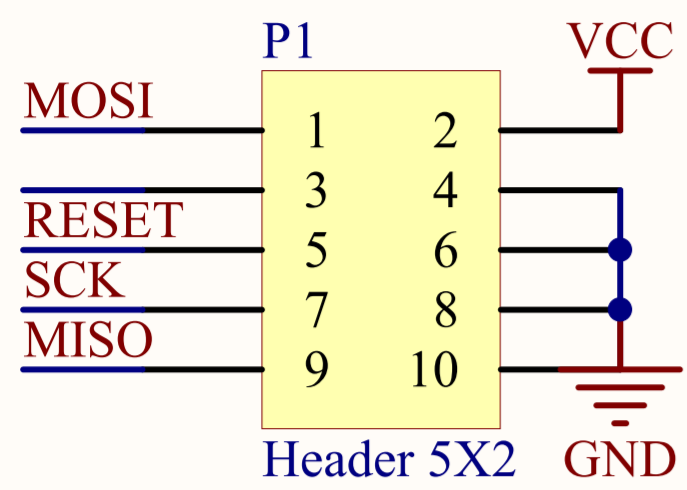

Power Header

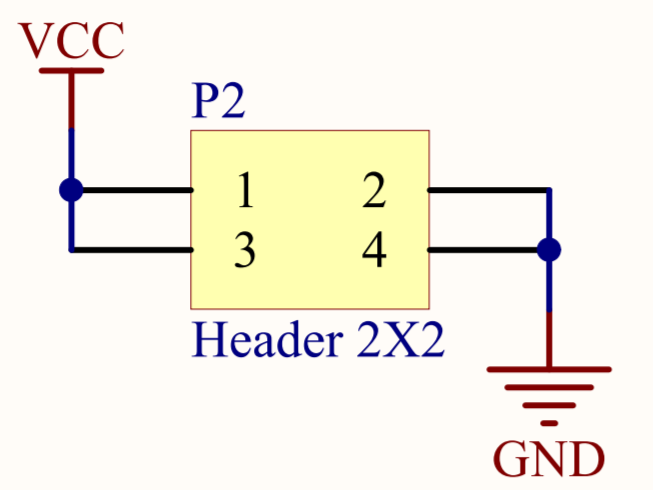

I2C Test Header

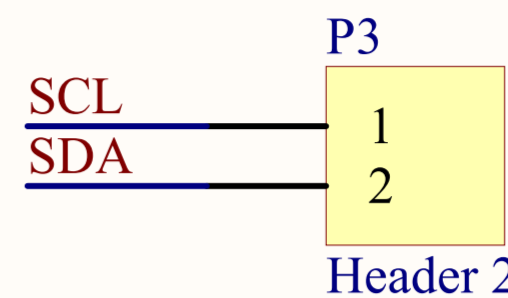

Microcontroller

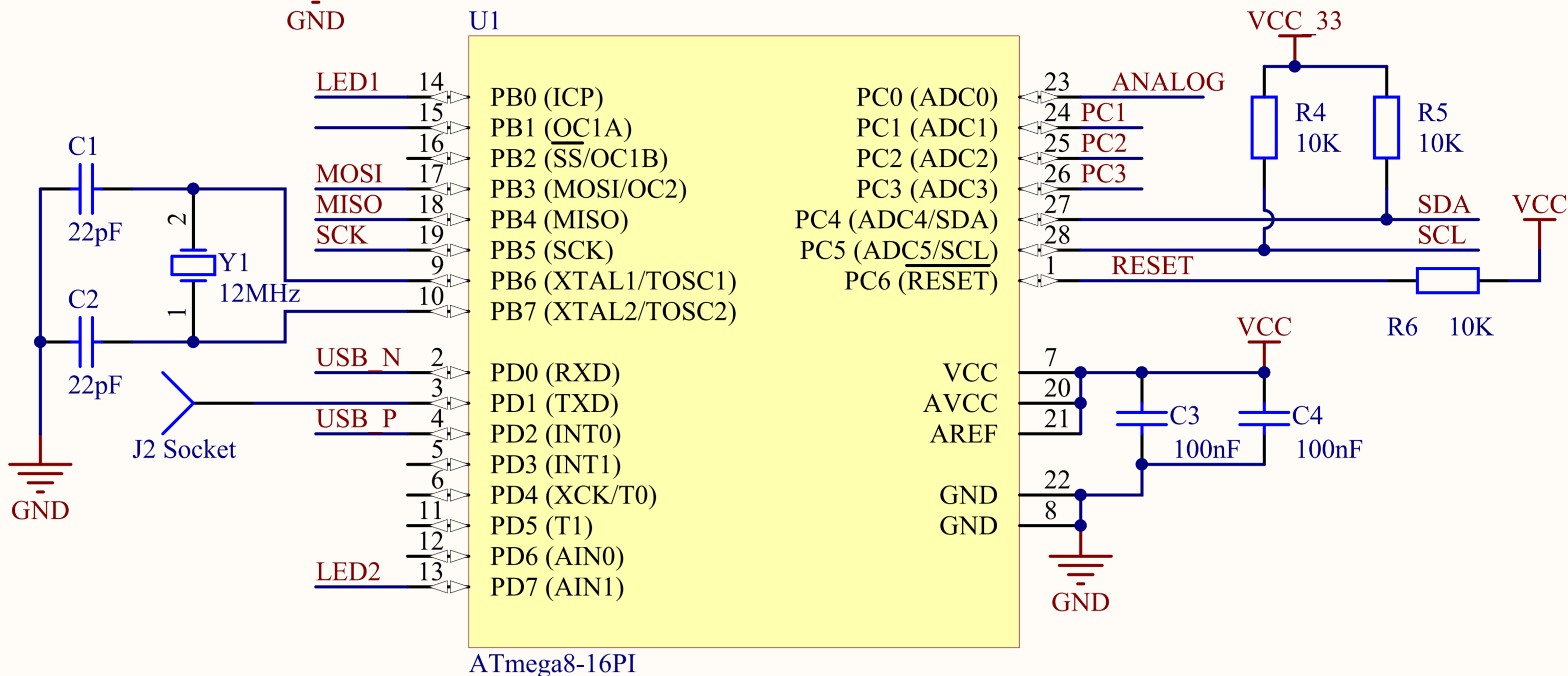

Extension Header

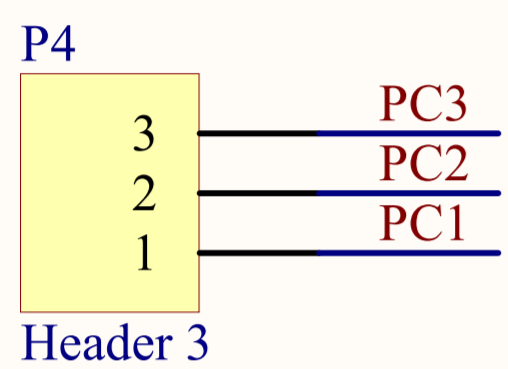

Power LED

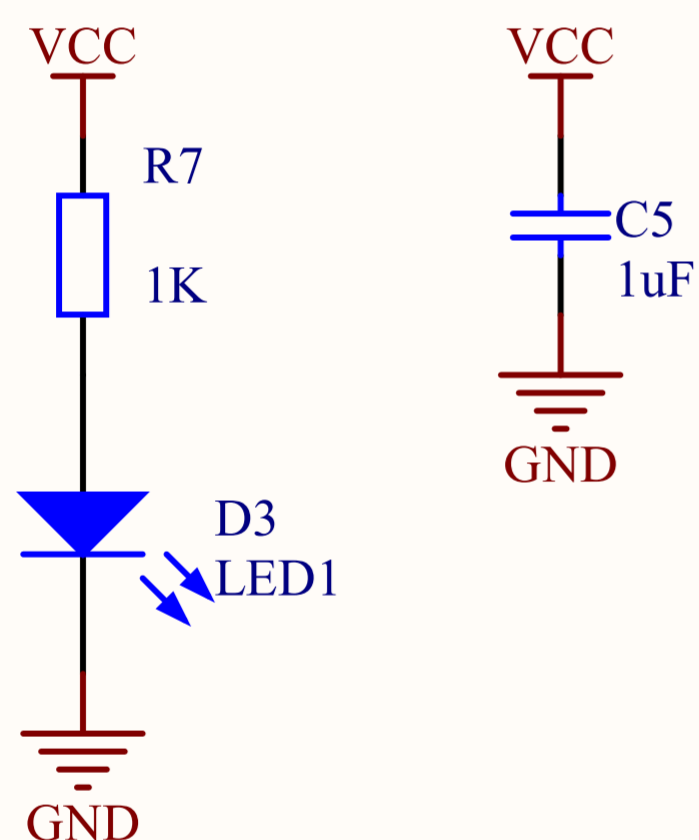

Angular Rate Gyroscope Module

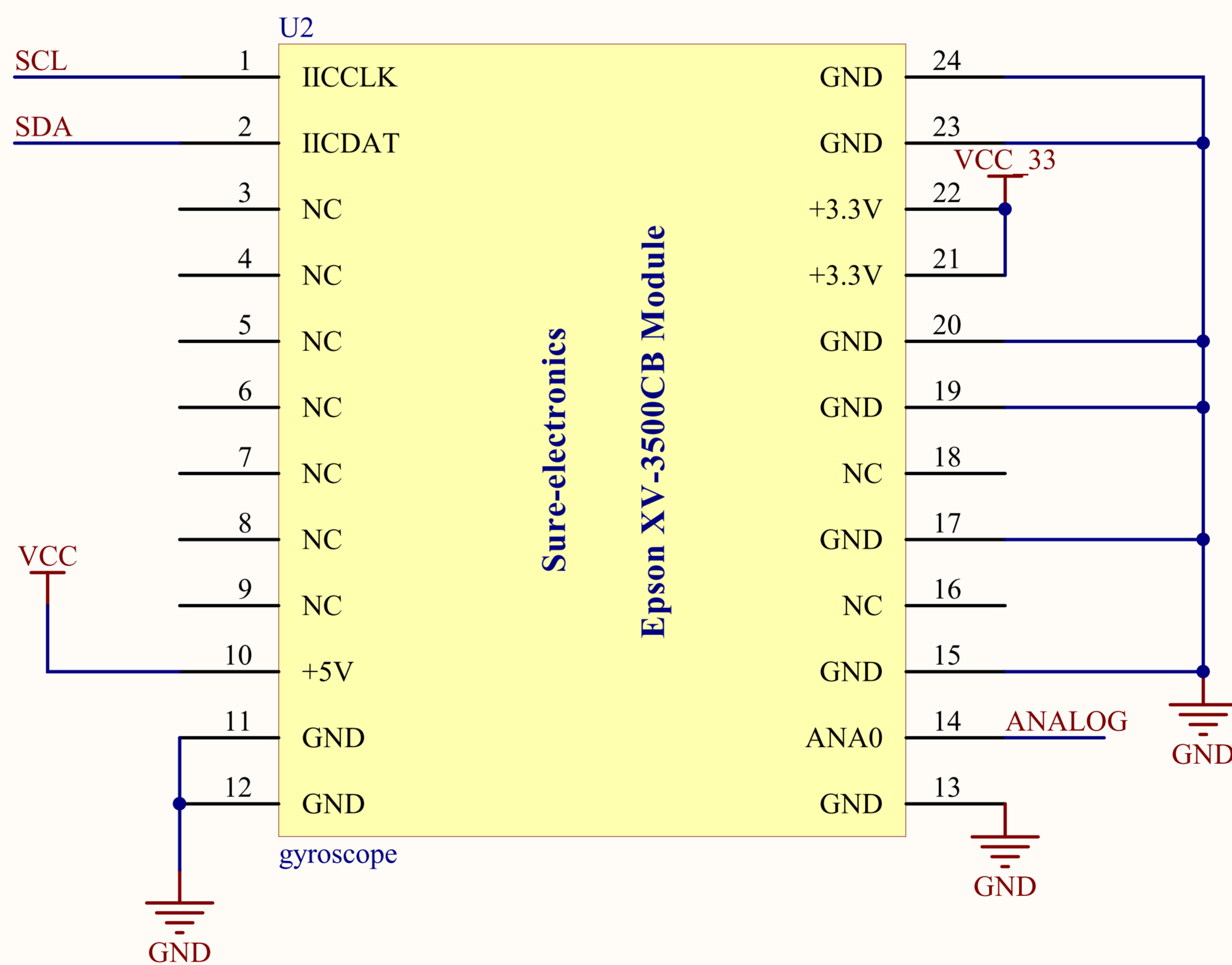

Status LED's

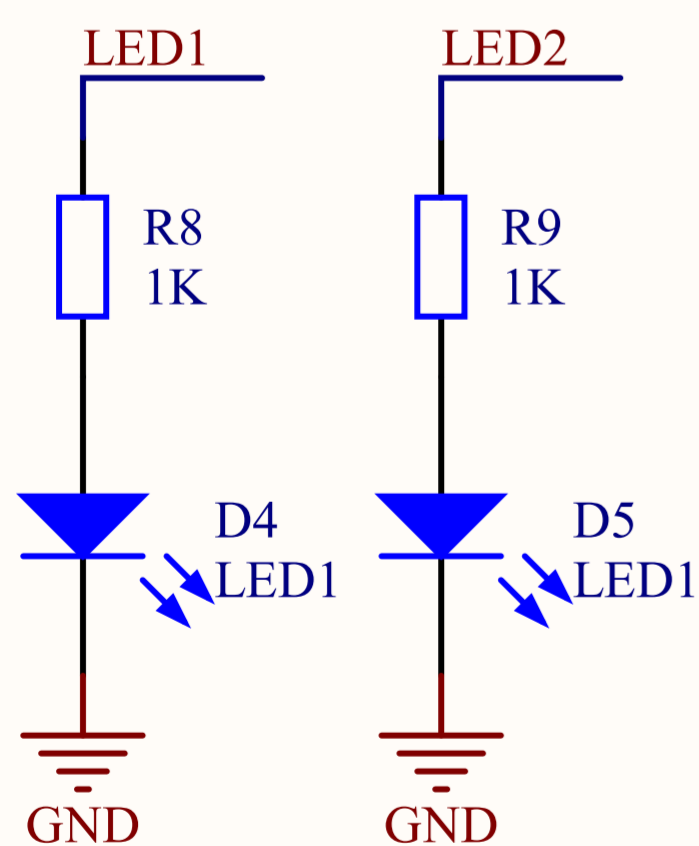

Title USB Gyro		
Size	Number 1	Revision 1.0
Date:	7/27/2009	Sheet 1 of 1
File:	C:\Documents and Settings\...\.usbgyro.SchDoc	Drawn By: Bianco Zandbergen